

**EFCOG / DOE
Electrical Safety
Improvement Project**

**Project Area 4 –Performance
Measurement**

**Electrical Severity Measurement Tool
Revision 1**

April 16, 2007

Electrical Severity Measurement Tool

Purpose: This tool is intended to determine the severity of an electrical energy event based on an evaluation of a series of electrical factors. The primary factors include: electrical hazard, environment, shock proximity, arc flash proximity, thermal proximity and any resulting injury(s) to affected personnel. This tool is also intended to assist DOE organizations in determining and classifying ORPS reportability.

Scope: This tool establishes a standardized approach for tracking and trending electrical energy events across the DOE complex. Specifically this approach provides a consistent method for the complex to determine the severity of an electrical event and to measure performance over a period of time. The Electrical Severity calculation is to be performed by an Electrical Subject Matter Expert (SME) with working knowledge of NFPA 70E.

Limitations: This tool is not intended to evaluate events that do not involve exposure to electrical energy. This tool establishes a metric that can be consistently applied to allow a DOE organization to compare relative performance against itself. Comparison of one organization's performance to another is considered inappropriate without further normalization due to anomalies and variables that may exist in work scope (e.g., D&D vs Research), environmental conditions, etc.

This tool is not intended to be used to develop electrical safety program requirements. Since NFPA 70E does not cover all electrical hazards found in the research laboratory, such as high current/low voltage, high voltage/low current, radiofrequency, and capacitors, there are portions of this document based on classification of electrical hazards used in the DOE Electrical Safety Handbook and laboratory programs. Thus, portions of this tool go beyond or supplement current national codes and standards. The intent of this tool is to provide a relative ranking of the severity of the exposure to electrical hazards.

User Guidelines

(1) The tool is not intended to cover all factors that contribute to an electrical incident. For example, the tool does not take into account (a) training, (b) work control (except wearing proper PPE), and (c) equipment maintenance. The tool is intended to give a relative rank of the severity of the injury, or potential for injury.

Consider only the data required by the Severity Equation.

(2) The tool should be used without speculation on what could have occurred, or “what ifs”. The tool is intended to give a quantitative, reproducible score of an event, no matter where or when it occurred. Ideally, the tool should give the same result regardless of the user.

Do not speculate about what “could have happened”.

(3) The tool is not intended to be the sole measure of the severity of a safety incident, but to give a measure of the electrical hazard component. There may be other hazards involved (e.g., confined space, radiological), other issues (e.g., lack of training, lack of engineering controls), and other similar management concerns.

Other factors may need to be considered in the overall event assessment.

(4) The tool gives a fairly low score for a dry hand, 120 V shock. There is varying opinions on this result, and considerable thought went into the tool development and pilot results. Consider that, across the country, there are estimated to be 100s of dry hand, 120 V shocks daily while performing everyday activities such as inserting a plug into a receptacle, especially across the fingers of one hand. It is very rare that such shocks result in injury or fatality, but it is important to record them, to look for trends or concerns. The tool does take into account the factors that can cause such shocks to be harmful or fatal, namely a wet environment.

A dry-hand, 120 V shock ranks low.

(5) Equipment failures, containing the electrical hazard, do not result in a worker exposure to the electrical hazard, thereby giving a score of zero. If the electrical energy escapes, such as no equipment ground in place, or inadequate arc flash containment, then there may be exposure if the worker is within the boundaries.

Equipment failures may not result in exposure to an electrical hazard.

Electrical Severity (ES)

Each electrical event is reviewed to determine its Electrical Severity (ES) using the following equation:

$$\text{Electrical Severity (ES)} = (\text{Electrical Hazard Factor}) * (1 + \text{Environment Factor} + \text{Shock Proximity}^1 \text{ Factor} + \text{Arc Flash Proximity}^1 \text{ Factor} + \text{Thermal Proximity}^1 \text{ Factor}) * (\text{Injury Factor})$$

¹Note that you cannot have both an Arc Flash Proximity Factor and a Thermal Proximity Factor. If the proper Personal Protective Equipment (PPE) is utilized while performing the work then these factors can be reduced to zero (refer to PPE Mitigation section).

The Electrical Severity (ES) is based on the following factors:

Electrical Hazard Factor	blue-no hazard	0
	green-low hazard	1
	yellow-moderate hazard	10
	orange-high hazard	50
	red-very high hazard	100

*The Electrical Hazard Factor is determined by classifying the source of electrical energy that the worker was exposed to during the event and then assigning a value to it, based on the **Electrical Hazard Classification Charts**² found in the back of this document and color coded as shown above.*

²The hazard classification charts cover five broad areas, facility power, R&D, capacitors, batteries, and rf. These charts, taken collectively, represent almost all of the electrical hazards found in electrical equipment. Consequently, all classes should be considered when identifying the hazards associated with any piece of electrical equipment. A single piece of equipment may have multiple electrical hazard classifications, and the worker may have been exposed to a combination of hazards. To aid hazard identification, each chart has cross-reference notes in the upper right hand corner. For example, the R&D chart has cross-reference notes to capacitance, battery, and facility hazard charts. Incident evaluators should have a thorough understanding of the equipment involved in the electrical incident. Consulting manuals and schematics and speaking with factory service representatives and SMEs are ways to ensure that all of the hazards are fully understood and that all the pertinent classes are taken into account.

Environment Factor	Dry	0
	Damp	5
	Wet	10

The Environment Factor³ is determined by analyzing the environmental condition found in the area of the event. The Environment Factor is determined in order to assess the level of severity at the time of the event. Human skin resistance can vary considerably from a dry location to one that contains conductive fluids (e.g., end mill misters present in a machine shop).

³Dry is indoors unless otherwise noted, Damp is outdoors unless otherwise noted, Wet is assumed when water, snow, or other conductive liquids were involved. Examples: Outdoors can be dry, in certain arid climates, and Indoors can be wet, in work conditions involving conductive fluids.

Shock Proximity Factor	Outside Limited Approach Boundary	0
	Within Limited Approach Boundary	1
	Within Restricted Approach Boundary	3
	Within Prohibited Approach Boundary	10

The Shock Proximity Factor is determined by performing a Shock Hazard Analysis using the approach boundaries in Table 130.2(C) of NFPA 70E. For further explanation of the Table below, refer to the 2004 NFPA 70E. The approximate distance of the worker(s) to the exposed energy source must be determined. All dimensions are distance from the exposed live part to the employee.

Table 1 - Thresholds for defining shock hazards.

Source	Includes	Thresholds	Hazard Classes
AC	60 Hz sub-rf 1 Hz to 3 kHz	> 50 V and > 5 mA	1.2, 1.3, 1.4, 1.5 2.2b(ac), 2.2c(ac), 2.2d(ac), 2.3(ac), 2.4(ac)
DC	all	> 100 V and > 40 mA	2.2c(dc), 2.2d(dc), 2.3(dc), 2.4(dc)
Capacitors	all	> 100 V and > 1 J	3.2b, 3.3b, 3.3c, 3.3d, 3.3e, 3.4b, 3.4c, 3.4d
Batteries	all	> 100 V	Could be in any Class, 4.0, 4.1, 4.2, 4.3
RF	3 kHz to 100 MHz	A function of frequency	5.2a, 5.2b

NOTE 1: It is possible for a worker to be exposed to more than one shock hazard at any given location.

NOTE 2: There may be other electrical hazards below the above shock thresholds (e.g., a thermal burn hazard). See Tables below.

NOTE 3: Injuries may result from startle reactions due to contact with energized components, even though there is no shock hazard, especially high voltage, low energy (e.g., Classes 2.1d and 3.1d)

NOTE 4: Shock and burn hazards from induced and contact rf currents become negligible above 100 MHz.

Shock Boundary Analysis for 60 Hz

Shock boundary analysis, including the determination of the Limited, Restricted, and Prohibited Shock Boundaries, is relatively easy, as it is based on the rms voltage of the exposed conductor, relative to ground (which is the assumed potential of the worker). Shock boundary tables are found in NFPA 70E for 60 Hz power, and can be adapted to dc, including batteries and capacitors. This table is taken from NFPA 70E, Table 130.2(C). Notes help to explain the content and use of the table.

Table 2 - Approach boundaries to live parts for shock protection, 60 Hz ac.

(1)	(2)	(3)	(4)	(5)
Nominal System Voltage Range, Phase to Phase	Limited Approach Boundary		Restricted Approach Boundary, Includes Inadvertent Movement Adder	Prohibited Approach Boundary
	Exposed Movable Conductor	Exposed Fixed Circuit Part		
< 50	Not specified	Not specified	Not specified	Not specified
50 – 300	3.05 m (10'0")	1.07 m (3'6")	Avoid contact	Avoid contact
301 – 750	3.05 m (10'0")	1.07 m (3'6")	304 mm (1'0")	25 mm (0'1")
751 – 15 kV	3.05 m (10'0")	1.53 m (5'0")	660 mm (2'2")	178 mm (0'7")
15.1 – 36 kV	3.05 m (10'0")	1.83 m (6'0")	787 mm (2'7")	254 mm (0'10")
36.1 – 46 kV	3.05 m (10'0")	2.44 m (8'0")	838 mm (2'9")	432 mm (1'5")
46.1 – 72.5 kV	3.05 m (10'0")	2.44 m (8'0")	965 mm (3'2")	635 mm (2'1")
72.6 – 121 kV	3.25 m (10'8")	2.44 m (8'0")	991 mm (3'3")	813 mm (2'8")
138 – 145 kV	3.36 m (11'0")	3.05 m (10'0")	1.1 m (3'7")	940 mm (3'1")
161 – 169 kV	3.56 m (11'8")	3.56 m (11'8")	1.22 m (4'0")	1.07 m (3'6")
230 – 242 kV	3.97 m (13'0")	3.97 m (13'0")	1.6 m (5'3")	1.45 m (4'9")
345 – 362 kV	4.68 m (15'4")	4.68 m (15'4")	2.59 m (8'6")	2.44 m (8'0")
500 - 550 kV	5.8 m (19'0")	5.8 m (19'0")	3.43 m (11'3")	3.28 m (10'9")
765 – 800 kV	7.24 m (23'9")	7.24 m (23'9")	4.55 m (14'11")	4.4 m (14'5")

Notes:

- 1) The symbol ' is used for feet and " for inches. Thus, 3'6" means 3 feet, 6 inches.
- 2) All dimensions are distance from exposed live parts to worker.
- 3) Voltage, Phase to Phase refers to three-phase power systems. This value also can be used for phase to ground, or conductor to ground voltage.
- 4) Exposed Movable Conductor means that the bare conductor can move (e.g., an overhead transmission line conductor). This is unlikely indoors.
- 5) Exposed Fixed Circuit Part means that the bare conductor or other circuit part is stationary and will not move. This is the most common Limited Approach Boundary value used.
- 6) The odd voltage ranges (e.g., 46 – 72 kV) were selected in NFPA 70E because of the typical voltages of utility transmission systems.
- 7) The odd distances in meters result from conversion of English system units (in use for decades) to metric.

Shock Boundary Analysis for DC

Shock Boundary values for dc are not found in NFPA 70E, but can be inferred because the principles of air breakdown distance are similar. Differences in the physics of air gap breakdown from 60 Hz ac to dc are small compared to the conservative values chosen for the boundaries. To determine a similar value for dc, the ac phase to phase voltage was converted to peak of a phase to ground. This would give a value that is 0.82 x rms value of the phase to phase voltage used in NFPA 70E. Thus, to use the values in the 70E table is more conservative than 70E. This table gives approach boundaries to live parts for dc, which is applicable to dc circuits, batteries, and capacitors. Notes help to explain the content and use of the table.

Table 3 - Approach boundaries to live parts for shock protection, dc.

(1)	(2)	(3)	(4)	(5)
Nominal Voltage Conductor to Ground	Limited Approach Boundary		Restricted Approach Boundary, Includes Inadvertent Movement Adder	Prohibited Approach Boundary
	Exposed Movable Conductor	Exposed Fixed Circuit Part		
< 100	Not specified	Not specified	Not specified	Not specified
100 – 300	3.05 m (10'0")	1.07 m (3'6")	Avoid contact	Avoid contact
301 – 750	3.05 m (10'0")	1.07 m (3'6")	304 mm (1'0")	25 mm (0'1")
751 V – 15 kV	3.05 m (10'0")	1.53 m (5'0")	660 mm (2'2")	178 mm (0'7")
15 – 45 kV	3.05 m (10'0")	2.5 m (8'0")	0.8 m (2'9")	0.44 m (1'5")
45 – 75 kV	3.05 m (10'0")	2.5 m (8'0")	1 m (3'2")	0.65 m (2'1")
75 – 150 kV	3.4 m (10'8")	3 m (10'0")	1.2 m (4'0")	1 m (3'2")
150 – 250 kV	4 m (11'8")	4 m (11'8")	1.6 m (5'3")	1.5 m (5'0")
250 – 500 kV	6 m (20'0")	6 m (20'0")	3.5 m (11'6")	3.3 m (10'10")
500 – 800 kV	8 m (26'0")	8 m (26'0")	5 m (16'5")	5 m (16'5")

Notes:

- 1) The symbol ' is used for feet and " for inches. Thus, 3'6" means 3 feet, 6 inches.
- 2) All dimensions are distance from live parts to worker.
- 3) Voltage is conductor to ground.
- 4) Exposed Movable Conductor means that the bare conductor can move (e.g., an overhead transmission line conductor). This is unlikely indoors.
- 5) Exposed Fixed Circuit Part means that the bare conductor or other circuit part is stationary and will not move. This is the most common Limited Approach Boundary value used.
- 6) The voltage ranges were simplified from NFPA 70E. Conservative values (e.g., the higher values) were chosen.
- 7) The distances were rounded up to generate simpler numbers.
- 8) It is unlikely that a worker will work near exposed conductors over 100 kV, dc.

Arc Flash Proximity Factor	Outside Arc Flash Boundary	0
	Inside Arc Flash Boundary	10

The Arc Flash Proximity Factor is determined by performing a Flash Hazard Analysis using one of the methods as described in NFPA 70E 130.3(A). The method used cannot differ from the method that the institution is using to determine Personal Protective Equipment (PPE) to protect against arc flash. The approximate distance of the worker to the energy source is used again to determine the arc flash hazard.

The Table for arc flash hazards below is based on IEEE 1584, which describes when an arc flash hazard is present.

Table 4 - Arc flash hazards.

Source	Includes	Thresholds	Hazard Classes
AC (facility)	50 and 60 Hz	<ul style="list-style-type: none"> • 120/240 V where system transformer ≥ 75 kVA and circuit breaker serving the equipment > 400 A <u>or</u> where system transformer ≥ 167 kVA. • 208Y/120 V where system transformer ≥ 150 kVA and circuit breaker serving the equipment > 400 A <u>or</u> where system transformer ≥ 300 kVA. • 480 V or 480Y/277 V where system transformer ≥ 300 kVA and circuit breaker serving the equipment > 400 A <u>or</u> where system transformer ≥ 1000 kVA. • Any system > 600 V <small>Note: Thresholds determined using formulas in IEEE Std 1584 Table E.1 and typical transformer impedances.</small>	1.2, 1.3, 1.4, 1.5
AC, R&D	1 – 3 kHz	> 250 V and > 500 A	2.4 (ac)
DC	all	> 250 V and > 500 A	2.4 (dc)
Capacitors	all	> 100 V and > 10 kJ	3.4b, 3.4d
Batteries	all	> 250 V and > 500 A	4.3
RF	NA	Not Applicable (NA)	

Thermal Proximity Factor

	<i>Power</i>	
	<i>1-30 kW</i>	<i>>30 kW</i>
No contact	0	0
Contact	3	10

The Thermal Proximity Factor is determined by performing a Thermal Hazard Analysis by analyzing whether a conductive media came into contact with an energized source. The hazard to the worker in this case is a thermal one, (e.g., burn received from holding a wrench that came into contact with a high current energy source). The severity is determined by human contact with the conductive media and the power available to the contacting media.

Table 5 - Thermal burn hazards, not included in shock and arc-flash hazards.

Source	Includes	Thresholds	Hazard Classes
AC, R&D	1 – 3 kHz	< 50 V and > 1000 W	2.2b
DC	all	< 100 V and > 1000 W	2.2a, 2.2b
Capacitors	all	< 100 V and > 100 J	3.2a, 3.3a, 3.4a
Batteries	all	< 100 V and > 1000 W	4.2, 4.3
RF	NA	NA	

PPE/Equipment Mitigation

Correct for Environment hazard	reduces the Environment Factor to 0
Correct for Shock hazard	reduces the Shock Proximity Factor to 0
Correct for Arc Flash hazard	reduces the Arc Flash Proximity to 0
Correct for Thermal hazard	reduces the Thermal Proximity Factor to 0

Reduces the appropriate factor(s) to zero when the proper equipment and/or PPE is utilized. Proper PPE means that it protects the worker from the electrical hazard associated with that factor and it has been tested and certified (if applicable) to do so. The type and ratings (if applicable) of PPE must be determined. Proper equipment means that the equipment being used has been designed to protect the worker from the electrical hazard associated with that factor.

Injury Factor	None	1
	Shock (no fibrillation), burn (1 st degree)	3
	Arc Flash/Blast, burn (2 nd degree)	5
	Shock resulting in effects on heart	10
	Permanent disability, burn (3 rd degree)	20
	Fatality	100

The Injury Factor is determined by the injury to the worker(s) involved in the event.

Electrical Severity Significance

The Electrical Severity (ES) equation generates scores from 0 to 310,000. This range provides an exponentially rising severity that, when based on a logarithmic scale, breaks down into 4 categories of significance (as shown below) Extreme, High, Medium and Low.

<u>Significance</u>	<u>Electrical Severity (ES)</u>	<u>Recommended ORPS Group 2 Significance Category</u>
Extreme	≥ 3301	1, 2
High	331 - 3300	3*
Medium	31 - 330	4**
Low	1 - 30	***Non-Reportable

* If contact with hazardous energy is made, report under Group 2 Significance Category 2.

** Currently not an option under ORPS Group 2 Criteria. If contact with hazardous energy is made, report under Group 2 Significance Category 2. If no contact is made with hazardous energy, then report under Group 10, Significance Category 4.

***Requires evaluation under ORPS Group 10 criteria.

For example, the Low (score 1-30) events are usually those items that truly did not pose a risk to the worker such as carpet shock and mishaps that were expected to happen in the work control document for which the worker was appropriately prepared for. Therefore, an event with a calculated ES value of 1-30 is not an electrical event.

The belief is that the Low (score 1-30) events are low enough in severity that they should be addressed on site by the contractor having them but may not add any overall value when reported through the ORPS system.

Electrical Severity Index (ESI)

The Electrical Severity Index (ESI) performance metric was developed to normalize the events against organizational work hours.

The ESI should be calculated monthly.

The rolling twelve month ESI average should also be calculated monthly to limit small period fluctuations.

Both the monthly ESI and the rolling twelve month ESI average should be tracked graphically.

The ESI is calculated when each event is weighted for severity and then averaged with other events to obtain a result representing performance.

The Electrical Severity (ES) is used as the weighting factor for each event in the Electrical Severity Indicator (ESI) metric below.

$$ESI = \frac{200,000[(ES_{event1}) + (ES_{event2}) + (ES_{eventN}) \dots]}{\text{(hours worked)}}$$

where:

ESI = Electrical Severity Index

200,000 = constant (man hours for a 100 person work force)

Event = electrical safety event

Hours worked = actual work hours for work population (as reported in CAIRs)

Note: same as hours used to calculate OSHA Recordable Case Rate (RCR)

ES = the Electrical Severity calculated above for a specific event.

The ESI is intended to utilize a similar approach to calculating RCR (source of work hours is same). *It assigns a numerical weighting factor to each event, the more risk or consequence associated with the event, the higher the weighting factor. ORPS reportable occurrences serve as basis for events.*

An evaluation should be performed to determine if the goal for continuous improvement is being met. An occurrence that results in electrical injury would be considered unsatisfactory performance for the year.

Hazard Assessment Charts and Recommended Controls

The hazard classification charts cover five broad areas, facility power, R&D, capacitors, batteries, and rf. These charts, taken collectively, represent most of the electrical hazards found in electrical equipment. Consequently, all charts should be considered when identifying the hazards associated with any piece of electrical equipment. A single piece of equipment may have multiple electrical hazard classifications, and the worker may have been exposed to a combination of hazards. To aid hazard identification, each chart has cross-reference notes in the upper right hand corner. For example, the R&D chart has cross-reference notes to capacitance, battery, and facility hazard tables. Incident evaluators should have a thorough understanding of the equipment involved in the electrical incident. Consulting manuals and schematics and speaking with factory service representatives and SMEs are ways to ensure that all of the hazards are fully understood and that all of the pertinent classes are taken into account. Some guidelines on use of the hazard classification charts are given. They are general, and there may be exceptions to each one:

- 1) If you do not understand these guidelines and your equipment, consult an electrical SME
- 2) All equipment gets its power from the facility (Classes 1.x) or batteries (Classes 4.x). Thus, equipment starts with one of those classes
- 3) Most small appliances, hand tools, and portable laboratory equipment plugs into Class 1.2. In general, if you can carry it, most likely it uses 120 to 240 V
- 4) Larger facility and laboratory equipment may use up to 480 V (Class 1.3). Often, if it is a large motor, or consumes significant power, it may be Class 1.3
- 5) All electronic equipment and much other R&D equipment converts facility power into dc. All dc power supplies have some capacitance. Thus, dc power supplies have hazards in Classes 2.x and 3.x. Both must be evaluated
- 6) All UPSs have hazards in Classes 4.x as well as 1.x, since they usually are tied into facility power (input), and produce facility type power (output)

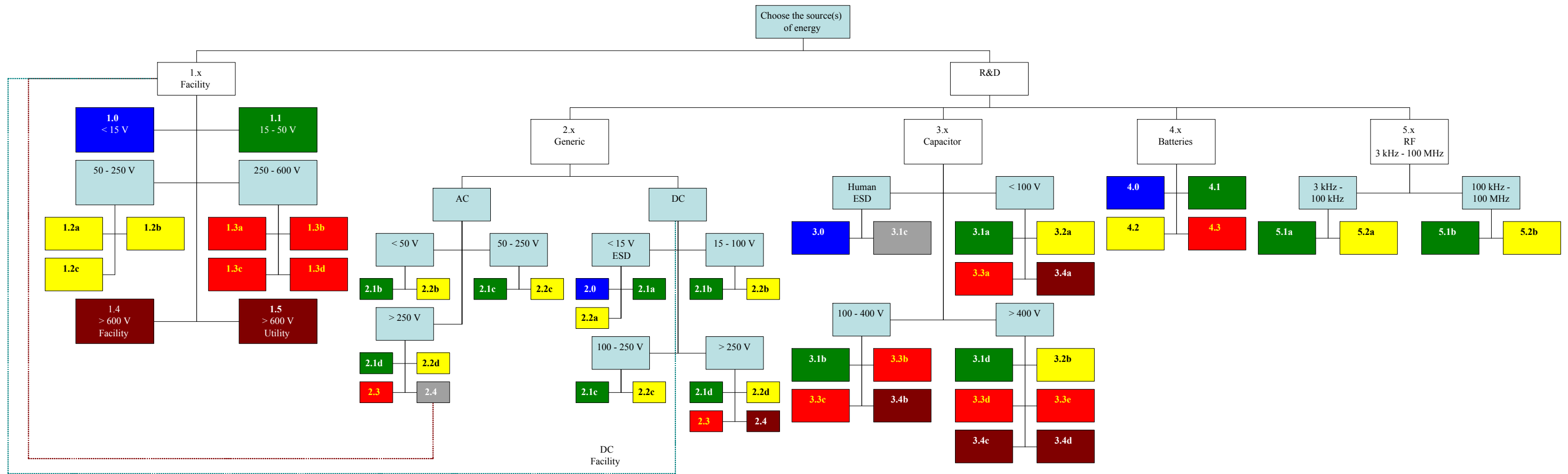



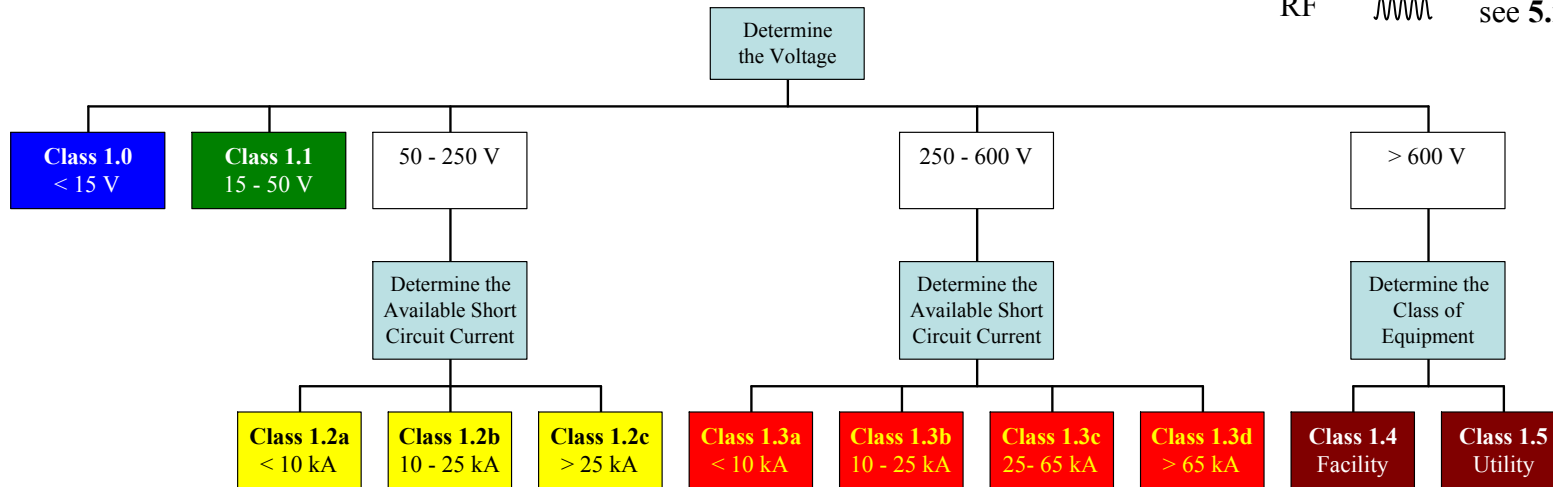

Chart 1 - Complete electrical hazard classification system showing 5 major groups and 54 Classes.

R&D see 2.x
 Capacitors  see 3.x
 Battery  see 4.x
 RF  see 5.x



Note: for DC facility power refer to Classes 2.x: R&D DC

Chart 2 - Hazard Classes 1.x, for 60 Hz power.

Notes on use of Chart 2 - Hazard Classes 1.x:

- (a) The voltage is the root mean square (rms) voltage for 60 Hz power
- (b) The current is the available fault current
- (c) Class 1.4 is work on facility circuits above 600 V
- (d) Class 1.5 is work on utility circuits above 600 V
- (e) For R&D (ac or dc, not 60 Hz), use hazard Classes 2.x
- (f) For capacitors, use hazard Classes 3.x
- (g) For batteries, use hazard Classes 4.x
- (h) For ac frequencies above 3 kHz (rf) use hazard Classes 5.x.

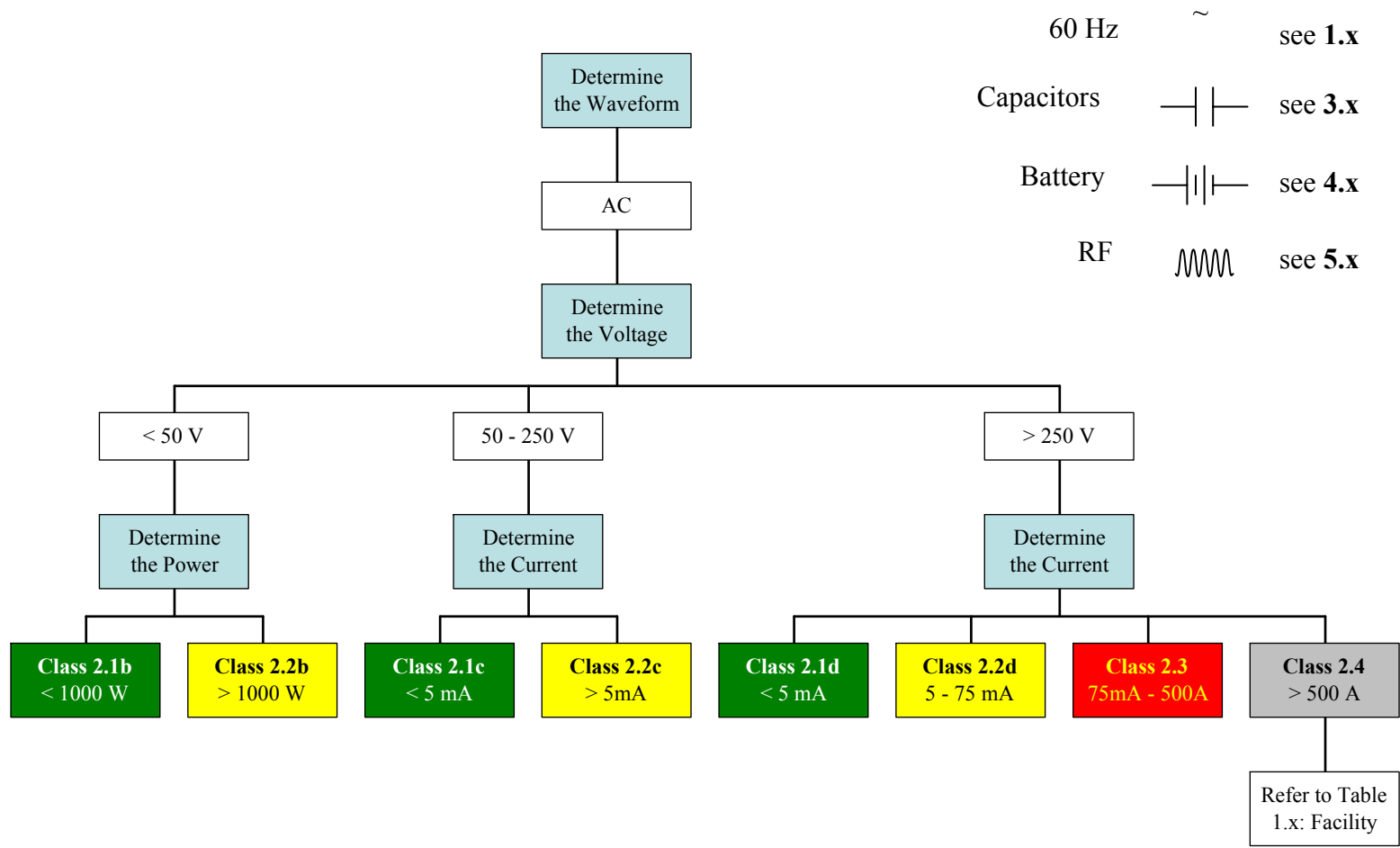

Chart 3 - Hazard Classes 2.x, ac R&D and electronic.

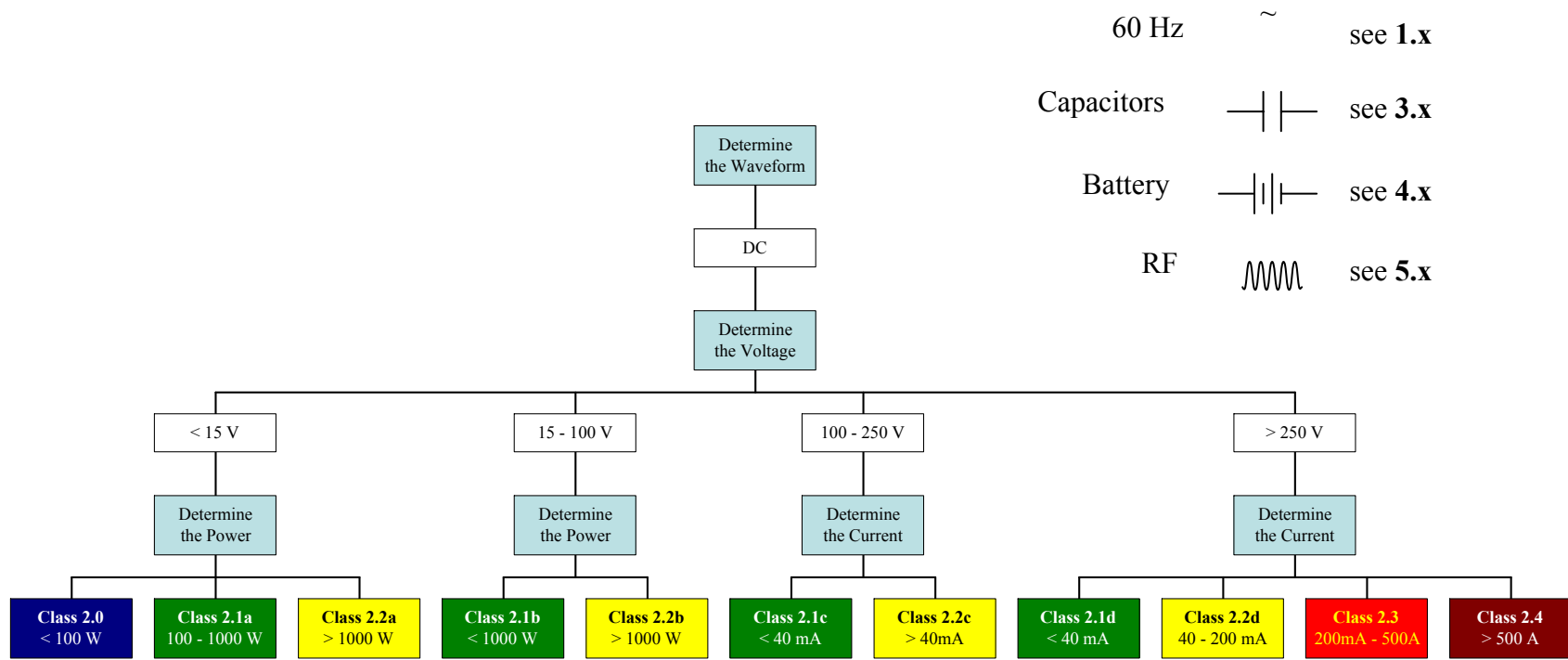

Chart 4 - Hazard Classes 2.x, DC R&D and electronic.

Notes on use of Charts 3 and 4, Hazard Classes 2.x:

- (a) This control Table is NOT to be used for 60 Hz power
- (b) The primary difference between Class 1.x and 2.x is the lack of available fault current in Class 2.x to create an arc-flash hazard. If significant fault current exists, Class 2.4, the worker must perform an arc-flash analysis, for ac or dc
- (c) AC R&D includes ac frequencies from 1 Hz to 3 kHz (sub rf ac), that is not 60 Hz power
- (d) Voltage is rms for AC or DC voltage
- (e) Power is available short-circuit power
- (f) Current is available short-circuit current
- (g) For 60 Hz facility power use hazard Classes 1.x
- (h) For capacitors use hazard Classes 3.x
- (i) For batteries use hazard Classes 4.x
- (j) For ac frequencies above 3 kHz (rf) use hazard Classes 5.x

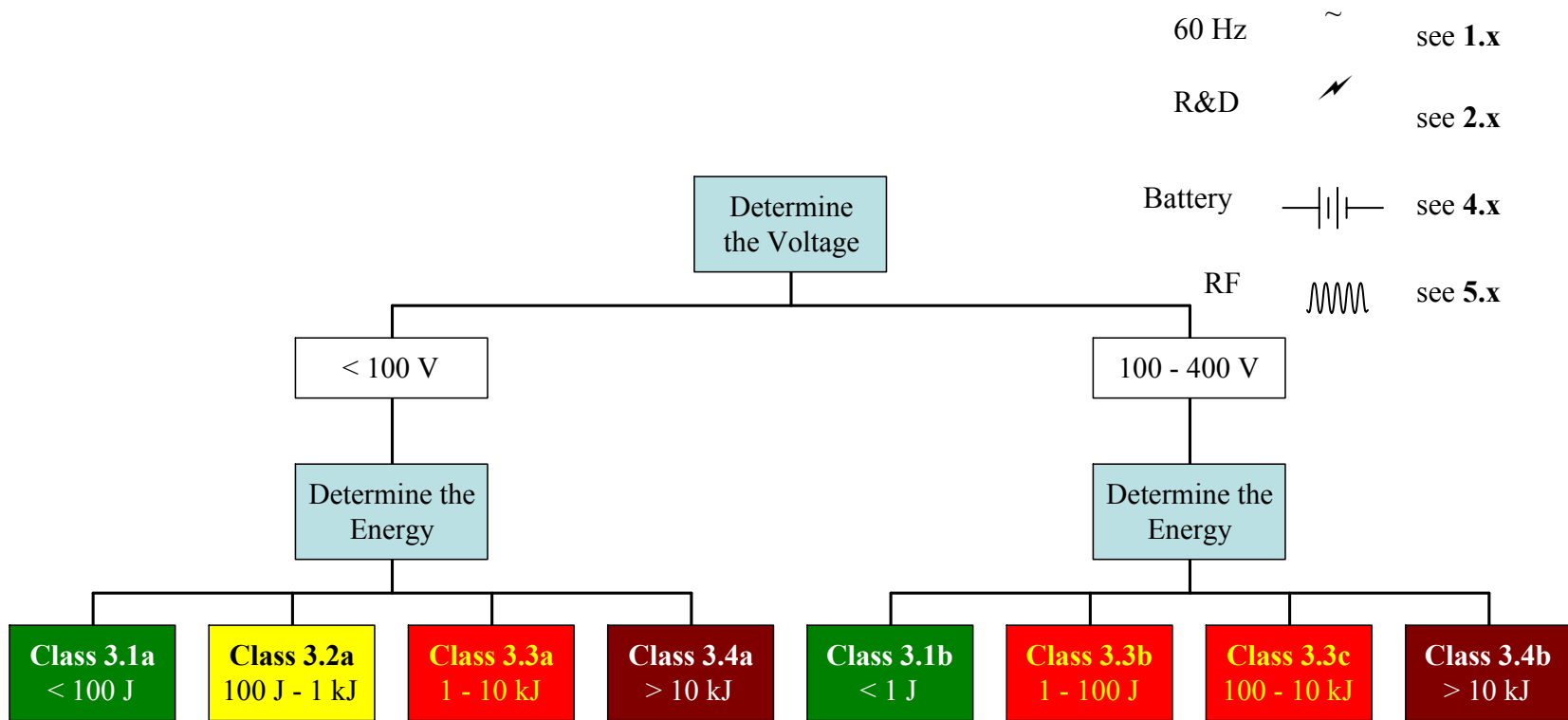

Chart 5 - Hazard Classes 3.x, capacitors, < 400 V.

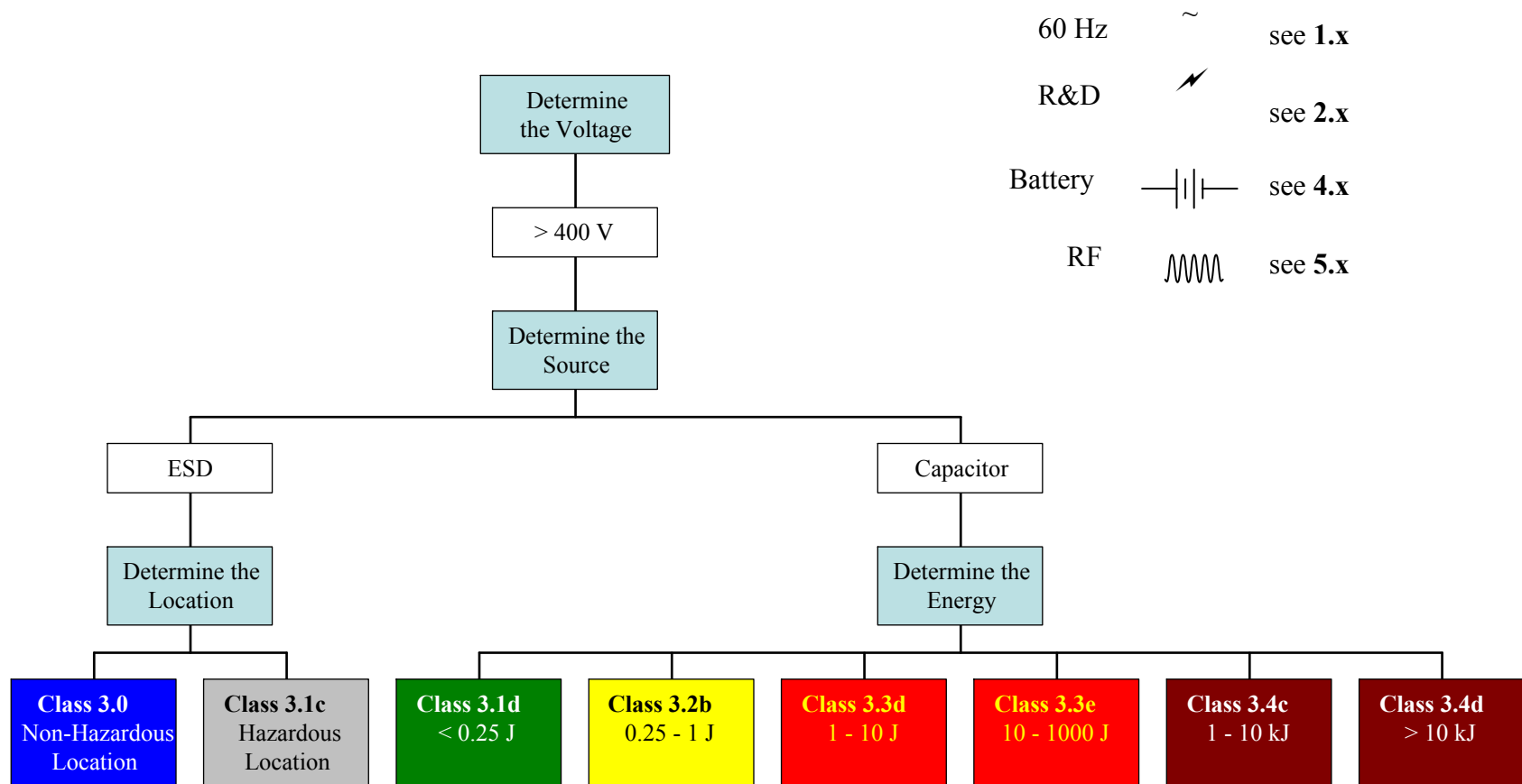
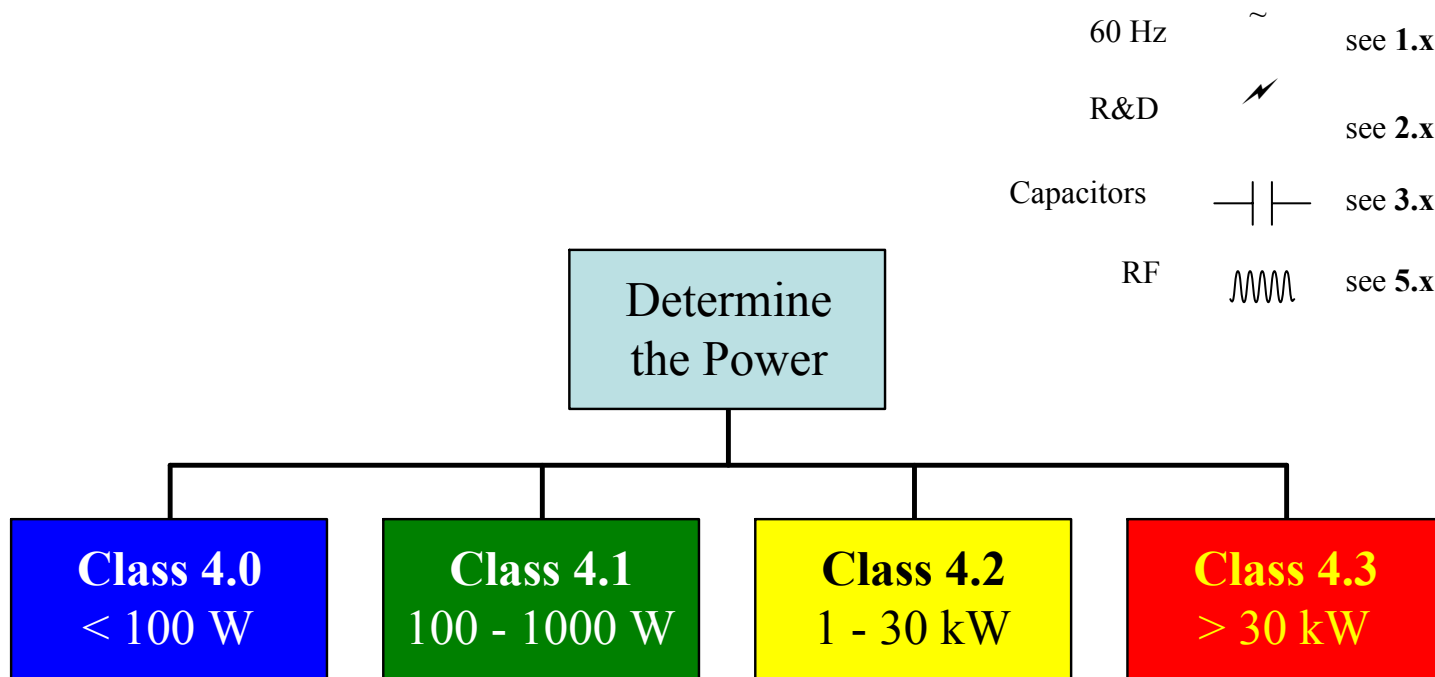

Chart 6 - Hazard Classes 3.x, capacitors, > 400 V.

Notes on use of Charts 5 and 6 - Hazard Classes 3.x:

- (a) Voltage is a_{rms} or dc maximum charge voltage on the capacitor
- (b) Energy is maximum energy stored in the capacitor as determined by $\frac{1}{2}CV^2$
- (c) For 60 Hz facility power, use hazard Classes 1.x
- (d) For R&D (not 60 Hz), use hazard Classes 2.x
- (e) For Batteries use, hazard Classes 4.x
- (f) For ac frequencies above 3 kHz (rf), use hazard Classes 5.x.



Note: > 100 V also refer to Table 2.x: R&D DC to classify the shock hazard.

Chart 7 - Hazard Classes 4.x, batteries and battery banks.

Notes on use of Chart 7 - Hazard Classes 4.x:

- (a) Power is the short circuit available power from the battery. This can be obtained by multiplying the short circuit available current by the battery terminal voltage. The short circuit available current can be obtained from the manufacturer's specifications
- (b) For 60 Hz facility power, use hazard Classes 1.x
- (c) For R&D (not 60 Hz), use hazard Classes 2.x
- (d) For capacitors, use hazard Classes 3x
- (e) For ac frequencies above 3 kHz (rf), use hazard Classes 5.x.

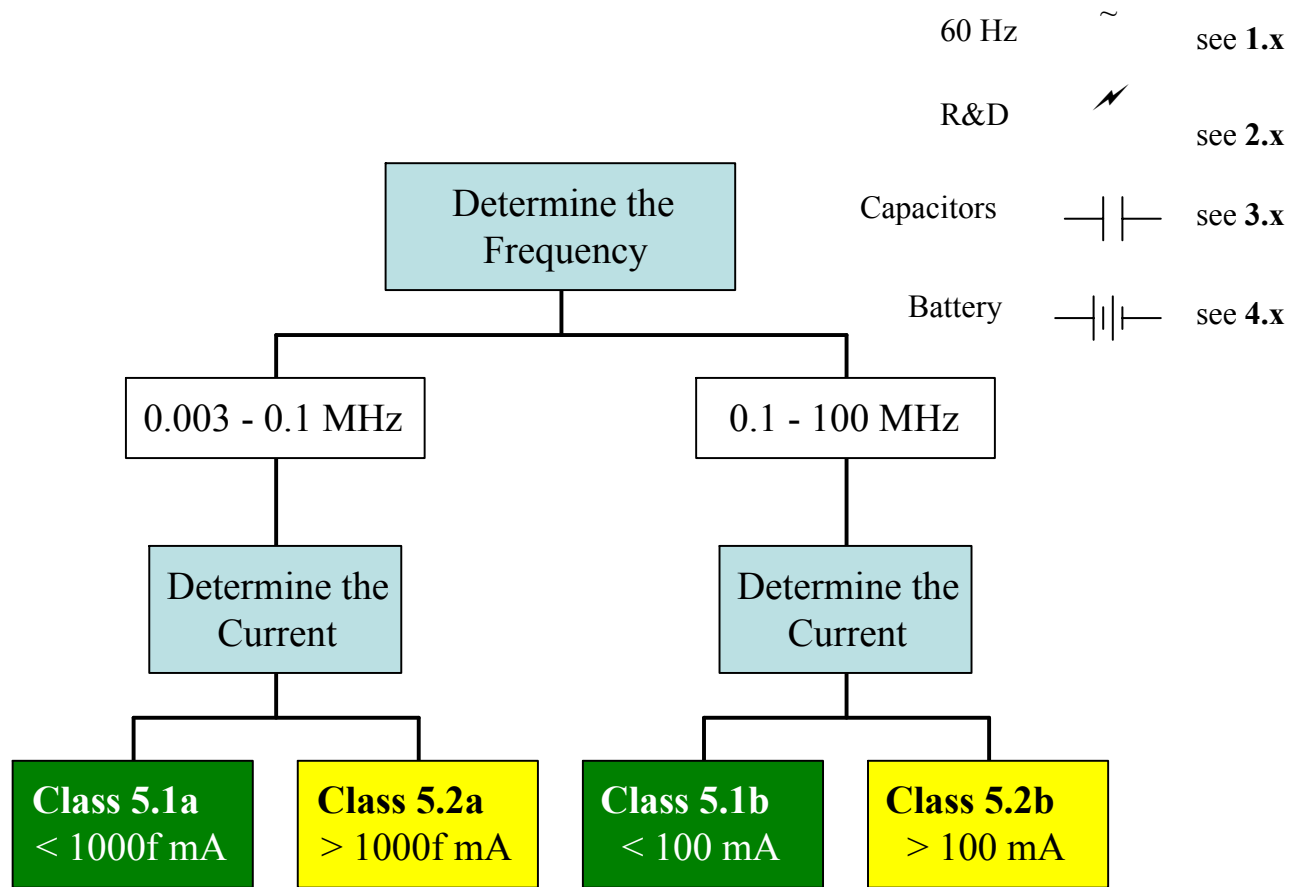

Chart 8 - Hazard Classes 5.x, rf circuits 3 kHz to 100 MHz (f is in MHz).

Notes on use of Chart 8 – Hazard Classes 5.x:

- (a) f in the Chart is frequency in MHz
- (b) Classes 5.x ONLY addresses the rf shock hazard. It does NOT address the exposure to electromagnetic fields
- (c) The allowable shock currents are much higher than 60 Hz (e.g., 100 mA is allowed for 100 kHz)
- (f) For 60 Hz facility power use hazard Classes 1.x
- (g) For R&D (not 60 Hz) use hazard Classes 2.x
- (h) For capacitors use hazard Classes 3x
- (i) For batteries use hazard Classes 4.x.

List of Acronyms

ac	alternating current
D&D	Decontamination and Decommissioning
dc	direct current
DOE	Department of Energy
EFCOG	Energy Facility Contractors Operating Group
ES	Electrical Severity
NFPA	National Fire Protection Association
PPE	Personal Protective Equipment
R&D	Research and Development
rf	radio frequency
rms	root mean square
SME	Subject Matter Expert
UPS	Uninterruptible Power Supply